



User manual Technical Parameters



4-quadrant controller multicom F144-MS-1V1C1TI6RO-3 F144-MS-1V1C1TI12RO-3



You can find the instructions for your KBR device at our download center.

<https://www.kbr.de/de/dienstleistungen/download-center>

Table of Contents

| | | |
|-----|---|----|
| 1 | Introduction | 4 |
| 1.1 | User Manual..... | 4 |
| 1.3 | Safety Notes..... | 6 |
| 1.4 | Product Liability | 7 |
| 1.5 | Disposal..... | 7 |
| 1.6 | Overvoltage and Lightning Protection..... | 7 |
| 2 | Functional Principle of the Controller | 8 |
| 3 | Control and Display Panel | 10 |
| 4 | Setting Range of the Configurable Parameters:..... | 14 |
| 5 | Installation and Electrical Connection of the System..... | 16 |
| 5.1 | General, very important information | 16 |
| 5.2 | Current transformer connection and measuring voltage..... | 16 |
| 5.3 | Current transformer dimensions..... | 16 |
| 5.4 | Standard connection diagram..... | 17 |
| 5.5 | Measuring voltage connection Ph-N..... | 18 |
| 5.6 | Measuring voltage connection Ph-Ph | 19 |

KBR Kompensationsanlagenbau GmbH does not accept any liability for any loss or damage resulting from printing errors in or changes to this manual.

In addition, **KBR Kompensationsanlagenbau GmbH** does not accept any liability for any loss or damage caused by defective devices or devices manipulated by the user.

Copyright 2021 by **KBR Kompensationsanlagenbau GmbH**
Subject to change.

| | | |
|--------|---|----|
| 6 | Commissioning the System | 20 |
| 6.1 | General notes on commissioning..... | 20 |
| 7 | Navigation and Device Displays..... | 22 |
| 8 | Device displays of the main menus | 24 |
| 9 | Description of the individual display windows | 26 |
| 9.1. | Initialization window:..... | 26 |
| 9.2 | Commissioning window if no stage power is programmed..... | 26 |
| 9.3 | Start menu window: | 29 |
| 9.4 | Stage state window: | 31 |
| 9.5 | Service window:..... | 32 |
| 9.6 | Commissioning window:..... | 33 |
| 9.7 | Switching performance window: | 35 |
| 10 | Notes on Troubleshooting..... | 42 |
| 11 | System and Safety Device Maintenance | 43 |
| 12 | Technical Data..... | 44 |
| 12.1 | Measuring and display values..... | 44 |
| 12.2 | Measuring accuracy..... | 45 |
| 12.3 | Measuring principle..... | 45 |
| 12.4 | Device memory..... | 45 |
| 12.5 | Limits:..... | 45 |
| 12.6 | Power supply..... | 45 |
| 12.7 | Hardware inputs and outputs..... | 46 |
| 12.7.1 | Hardware inputs..... | 46 |
| 12.7.2 | Hardware outputs | 46 |
| 12.8 | Electrical connection..... | 47 |
| 12 | Selection of cables and fuses | 49 |
| 14 | Data Point Description for the Modbus Protocol..... | 50 |
| 14.1 | Modbus commands supported..... | 51 |
| 14.2 | Data formats..... | 51 |
| 14.3 | Interface parameters..... | 54 |
| 14.4 | Device settings | 54 |
| 14.5 | Data points..... | 60 |
| 15 | Device information | 63 |

1 Introduction

Thank you for choosing this KBR quality product.

To become familiar with the operation and programming of the device and to use the full range of functions of this high-quality product at all times, you should read this user manual carefully.

The individual chapters explain the technical details of the device and show how damage can be avoided through proper installation and commissioning.

1.1 User Manual

This user manual describes the device version multicom F144-3. This user manual must be accessible to the user at all times (e.g. in the switchgear cabinet). Even if the device is resold to third parties, the manual remains an inherent part of the device.

Although the utmost care has been taken in writing this user manual, errors may still occur. We would be very grateful if you would notify us of any errors or unclear descriptions you may notice.

1.2 Safety Keys

This manual contains instructions that you must follow for your personal safety and to avoid material damage. These instructions are identified by a warning sign or information symbol, depending on the degree of hazard they warn about.



DANGEROUS VOLTAGE

„Warning“ means that death, major injuries or damage may occur if suitable safety precautions are not taken.



CAUTION

„Caution“ means that minor injuries or damage may occur if the appropriate safety precautions are not taken.



NOTE

„Note“ is an important piece of information on the product, its operation or the respective part of the operating instructions to which special reference is being made.

Disclaimer

The contents of these operating instructions have been carefully reviewed in terms of the hardware and software described. Nonetheless, deviations cannot be ruled out, and the manufacturer cannot guarantee 100% conformity. The specifications made in these operating instructions are reviewed on a regular basis; any corrections required will be included in the next revision.

1.3 Safety Notes

In order to prevent operating errors, device operation is kept as simple as possible. This will enable you to start your device up quickly.

It is in your own interest to read the following safety instructions carefully. The applicable DIN/VDE regulations must be observed for installation!

Power supply connection, setup and operation of the device must be performed by qualified personnel only. Qualified personnel as defined in the safety notes in this user manual are those authorized to set up, ground and mark devices, systems and circuits in accordance with applicable standards and regulations.

To prevent fire and electric shock, do not expose the device to rain or moisture!

Before connecting the device to the power supply, check whether the local power supply conditions comply with the specifications on the device nameplate.



CAUTION

Incorrectly connecting the device can damage it.

For device connection, the data given in the connection diagram must be complied with (see chapter “Connection diagram”) and the connection lines must be voltage-free. When wiring, always ensure that all wiring material used is neither damaged nor defective and that the polarity is correct!

Proper and safe operation of the product requires correct transport, storage, installation and assembly as well as careful operation and maintenance.

If the device has any visible damage it is considered unfit for use and must be disconnected from the power supply!

Troubleshooting, repairs and maintenance work may only be carried out at our plant or after contacting our customer service team. If the device is opened without authorization, any warranty or guarantee claim is forfeited. Correct functioning can no longer be guaranteed!

Opening the device may expose live parts. Capacitors in the device may still be charged, even if the device has been disconnected from all power sources. Do not operate open devices under any circumstances!

Systems that are at risk from lightning strikes must feature lightning protection for all input and output lines.

1.4 Product Liability

You have purchased a high-quality product. Only top-quality components with exceptional reliability are used.

Each device undergoes a long-term test before delivery.

With regard to product liability, please see our general terms and conditions for electronic devices, which you can read at www.kbr.de.

The warranty on device characteristics only applies if the device is operated in accordance with its intended use!

1.5 Disposal

Please dispose of defective, out-of-date or no longer used devices properly.

If required, we will dispose of the device for you.

1.6 Overvoltage and Lightning Protection

To protect your purchased high-quality devices from damage, we strongly recommend that you take overvoltage protection measures. Protect control voltage inputs, pulse and bus lines.

2 Functional Principle of the Controller

The controller's microprocessor records the mains voltage and current consumption of the entire plant by measuring transformer inputs (A/D converter) and, on the basis of this, calculates the active and reactive power ratio of the mains. The controller operates in four quadrants.

■ **Energy recovery in generator operation is detected and indicated by a "G" flashing on the LCD display. During this time, compensation to $\cos \phi$ 1.00 (output $\cos \phi$) is performed. To prevent alternating switching operations, this target $\cos \phi$ is maintained for 15 minutes after generator operation.**

The compensated power required for the target $\cos \phi$ is calculated continuously. If the power difference corresponds to the set hysteresis (switch-on and switch-off hysteresis), the stages are switched depending on the required compensation power. Manually switched stages are, however, not included in the optimization. In case of identical stages with identical power, the stage that has been switched off for the longest time is switched on.

Having fewer switching operations results in optimum adjustment. Even for large systems, sensitive controls can be set up with just a few modules. Stage ratios do not need to be considered. After compensation, switching operations are interrupted for a configurable time. To prevent alternating switching operations, you can increase the stage switch-off delay by up to 150% of the smallest stage's power.

In low load operation (secondary measuring current under the limit), the stages are switched off after the set delay time.

The integrated temperature measurement input monitors the temperature in the reactive power Compensation system and causes the fan to be switched on if a predefined temperature threshold is exceeded and switched off again when the temperature drops below the reset temperature.

To prevent the fan from switching unnecessarily often, it has a run-on time of 30 minutes. You can switch the fan (relay output 6 or 12 depending on the device version) on or off permanently using the "Stage status" menu. If you select "Auto", the fan output is controlled by the temperature measuring input.

You can also protect the system by defining a switch-off temperature. This makes it possible to switch stages off in time if there is a risk of damage due to overheating. Once the temperature drops below the reset temperature, the stages are switched on again one after the other.

The settings are saved on an EEPROM so that they are not lost in the event of a power failure.

The measuring cycle of the controller used to record the necessary network parameters takes approx. 20 ms.



NOTE

Limit for overvoltage switch-off = measuring voltage + 10% (taking the measuring voltage ratio into account). This value cannot be changed and serves to protect the compensation system.

In the event of an error, the compensation stages are switched off. The alarm relay switches and "Overvoltage" is displayed.



CAUTION

The discharge times are automatically predefined for the following programmed stage powers. However, these must be checked and corrected if they differ from the capacitor specifications.

| Capacitor power | Discharge resistance | Discharge time |
|---------------------|----------------------|----------------|
| 0.1 kvar – 9.9 kvar | 300 kOhm | 60 seconds |
| 10 kvar – 19.9 kvar | 300 kOhm | 120 seconds |
| 20 kvar and above | 300 kOhm | 180 seconds |

3 Control and Display Panel

multicomp F144-3 Eco 6-stage

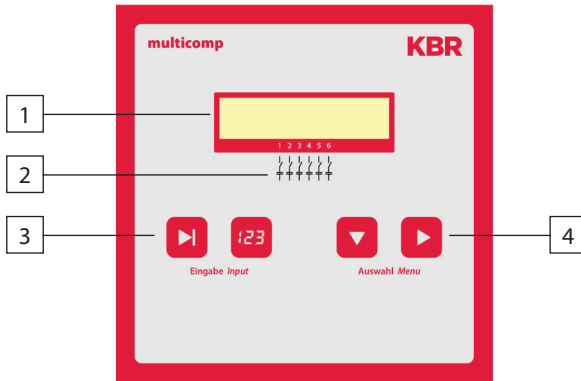



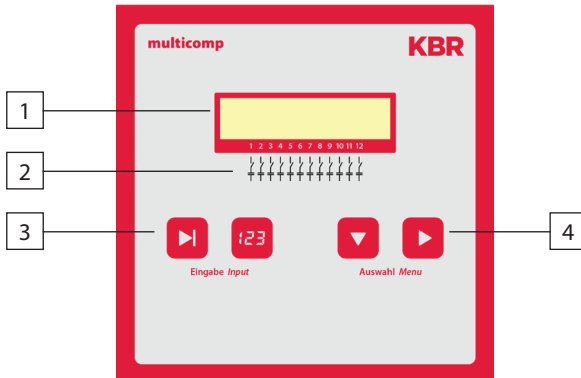

multicomp F144-3 Eco 12-stage



Operating elements:

- 1 LCD displaying the current status and user prompts
- 2 Number of possible controller output lines
- 3 Two sensor buttons for parameter configuration
- 4 Two sensor buttons for menu selection

General notes on operating the sensor buttons:

| | |
|---|--|
|  button | Start configuration and reset input |
|  button | Change values during configuration |
|  button | Navigate through submenus |
|   | Navigate through main menus and save button during configuration |

Button combinations:

| | |
|---|--|
|  and  buttons | Delete accumulated values and reset the system |
|---|--|

Default controller settings after reset:

| | |
|------------------------------------|--|
| ■ Consumption target cos phi: | 0.95 inductive |
| ■ Recovery target cos phi: | 1.00 (cannot be changed) |
| ■ Alarm cos phi: | 0.92 inductive |
| ■ Main transformer current: | Primary current 1000 A Secondary current 5 A |
| ■ Measuring voltage: | Primary voltage 400 V Ph-Ph (corresponds to 230V Ph-N) Secondary voltage 400 V Ph-Ph (corresponds to 230V Ph-N) |
| ■ Rot. field U: | L1-N |
| ■ Rot. field I: | L1 |
| ■ Current attenuation coefficient: | 2 |
| ■ Voltage attenuation coefficient: | 2 |
| ■ Attenuation coefficient Qmiss: | 2 |
| ■ Alarm delay: | 20 minutes (1200 s) |
| ■ Idle time: | 30 seconds |
| ■ Switching interval: | 8 seconds |
| ■ Hysteresis connection: | 100% of lowest stage power |
| ■ Hysteresis switch-off: | 100% of lowest stage power |
| ■ Switching performance Priority | Operation cycles, 24hours Switching off |
| ■ Operating cycle limit: | 80000 |
| ■ Operating cycle count: | Activated by set limit |
| ■ Stage switching mode: | Automatic |
| ■ Sampling rate: | Automatic |

| | |
|---|---|
| ■ Harmonics monitoring: | Activated by set limit |
| ■ Limit THD: | 8% |
| ■ Stage power: | Not set |
| ■ Stage power monitored: | Deactivated |
| ■ Discharge time: | 180 seconds |
| ■ Password: | No password (9999, meaning all functions are accessible) |
| ■ Language display: | English |
| ■ Contrast setting: | 4 |
| ■ Brightness setting: | 5 |
| ■ Dimmer brightness: | 0 |
| ■ Low load limit: | 15 mA |
| ■ Low load delay: | 60 minutes |
| ■ Temperature measurement: | On |
| ■ Relay 6/12 as stage or fan: | Fan |
| ■ Alarm relay as error message or fan: | Error message |
| ■ Fan switch-on temperature: | > 28 °C |
| ■ Fan switch-off temperature: | < 23 °C |
| ■ System switch-off temperature: | > 48°C |
| ■ System switch-on temperature: | < 43°C |
| ■ Learning mode menu display: | Off |
| ■ Key sounds: | On |

Error message dialog after reset:

| | |
|---------------------------------|-------------------------|
| No measuring voltage: | Message and alarm relay |
| No stage power: | Message and alarm relay |
| Facility too small: | Message and alarm relay |
| THD too high: | Message and alarm relay |
| Operating cycle limit exceeded: | Message and alarm relay |
| No measuring current: | Message and alarm relay |
| Low load operation: | Message and alarm relay |
| Temperature switch-off: | Message and alarm relay |

The controls in the compensation systems are preset.

- The following parameters need to be checked or set:
- Target cos phi in accordance with the electricity supplier regulations (for kVA tariff cos phi = 1)
- Primary current and secondary current in accordance with input current transformer.
- Voltage transformer ratio, if required

**NOTE**

Upon delivery, the bus protocol is set to:

Modbus RTU, baud rate 38400, parity even

This setting can only be changed manually on the device.

Performing a "Reset to default settings" has no effect on changed settings.

4 Setting Range of the Configurable Parameters:

Stage state:

Stage switching mode Automatic, Manual off, Manual on

Commissioning:

Password 4 digits, numerical, no password = 9999
(meaning all functions are accessible)

Primary current 1 A to 999999 A

Secondary current 1 and 5 A

Consumption target $\cos\phi$ ind. 0.80 to cap. 0.80

Recovery target $\cos\phi$ ind. 1.0 (cannot be changed)

Primary voltage 1 V to 99999 V Ph-Ph

Secondary voltage 1 V to 999 V Ph-Ph

Rot. field U L1N, L2N, L3N, L12, L23, L31

Rot. field I L1, L2, L3, -L1, -L2, -L3

Stage power learning mode Yes, No

Stage power 0 to 999.9 kvar

Discharge time 0 to 999 sec.

Switching performance:

Hysteresis connection 70 to 150 %

Hysteresis switch-off 70 to 150 %

Switching performance Priority Operation cycles, runtime

Alarm relay time 3 to 3000 sec.

Idle time 0 to 300 sec.

Switching interval 0 to 10 sec.

FTS alarm $\cos\phi$ ind. 0.70 to 1.0

Attenuation coefficient Q_{miss} 0 to 9

Attenuation coefficient voltage 0 to 9

Attenuation coefficient current 0 to 9

Error message dialog:

| | |
|--------------------------------|------------------------------|
| No measuring voltage | The settings Message or |
| No stage power | Alarm relay or Message and |
| Facility too small | Alarm relay or Off |
| THD too high | is identical for all errors! |
| Operating cycle limit exceeded | |
| No measuring current | |
| Light load | |
| Temperature switch-off | |

Extras:

| | |
|--|---|
| Display language | German, English, French, Spanish |
| THD limit | 0 to 10%, harmonics monitoring can be disabled (0%) |
| Operating cycle limit | 0 to 999999 (0 = deactivated) |
| Sampling rate | Automatic, fixed 50 Hz, fixed 60 Hz |
| Stage power monitoring | Yes, No |
| Reset | Run |
| Contrast setting | 0 to 10 |
| Brightness setting | 0 to 9 |
| Dimmer brightness | 0 to 9 |
| Low-load limit | 15 mA, 50 mA |
| Light load delay | 1 minute to 60 minutes |
| Temperature measurement | On / Off |
| Relay 6 or 12 (depending on the controller version) | Compensation stage, fan relay |
| Alarm relay | Error message, fan relay |
| Fan switch on temperature | > 0 °C to 60 °C |
| Fan switch off temperature | < 0 °C to 60 °C |
| Switching threshold system off | > 0 °C to 60 °C |
| System switch on temperature | < 0 °C to 60 °C |
| Bus mode | Modbus (eBus for production) |
| Learning mode menu display | On / Off |
| Key sounds | On / Off |

5 Installation and Electrical Connection of the System

5.1 General, very important information

- Tighten all screws and connections. Failure to do so will void the warranty.
- Install and operate the device in accordance with the applicable VDE regulations (in particular VDE 0100) and the electricity supplier's regulations.
- Connection cross-sections and fuse protection table: see attachment

5.2 Current transformer connection and measuring voltage

If possible, mount the transformer in the phase that corresponds to L1 of the compensation system (determine by means of voltage measurement). All capacitor and consumer currents must be determined. In case of unbalanced phase load (small systems), install the transformer in the phase with the highest load.

- P1 (K) to energy supply (indicated on the transformer).
- P2 (L) to load outputs
- S1 (k) with terminal k (controller terminal 20) and
- Connect S2 (l) to terminal l (controller terminal 21) in the compensation system (use a two-color cable!).

Wire cross section: up to 3 m = 1.5 mm², up to 6 m = 2.5 mm². For longer distances, we recommend using a 1 A transformer. The controller is designed for connection to 5 A and 1 A transformers; switching is done by firmware.

If you use existing transformers, the current paths must always be connected in series.

The secondary transformer current needs to be at least 15 mA. For lower currents, no capacitors are connected ("No measuring current" is displayed).

Connect the measuring voltage in accordance with the connection diagram.

5.3 Current transformer dimensions

The current transformer is designed on the basis of the current consumption of the consumers, not the capacitor current. If other measuring devices are connected to a transformer in addition to the reactive power controller, the transformer power needs to be dimensioned accordingly. Losses also occur in the current transformer cable that need to be considered if there are long distances between the transformer and the controller.

5.4 Standard connection diagram



NOTE

When connecting the phase (L1) to terminal 1 and the neutral conductor (N) to terminal 2 (Ph-N 100V – 240V+/-10 % 50Hz/ 60 Hz/DC) the safety device and the disconnector in the supply line to terminal 2 (N) are not required.

The safety device and the disconnector to terminal 2 (N) are only required for the following connection variants:

Alternating voltage:

Terminal 1 (L1) and terminal 2 (L2):

US1 Phase-Phase 100V - 240V +/-10% 50Hz/60 Hz

Direct voltage:

Terminal 1 (+) and terminal 2 (-):

US1 100V - 240V +/-10% DC

Connection variants of the power supply

| Terminal 1 | Terminal 2 | Voltage | Safety device and disconnector to Terminal 2 required |
|------------|---------------------|--------------------------------|---|
| | | Power supply unit US1 | |
| Phase L | Neutral conductor N | 100V - 240V +/-10% AC 50/60 Hz | No |
| Phase L1 | Phase L2 | 100V - 240V +/-10% AC50/60 Hz | yes |
| + | - | 100V - 240V +/-10% DC | yes |

5.5 Measuring voltage connection Ph-N

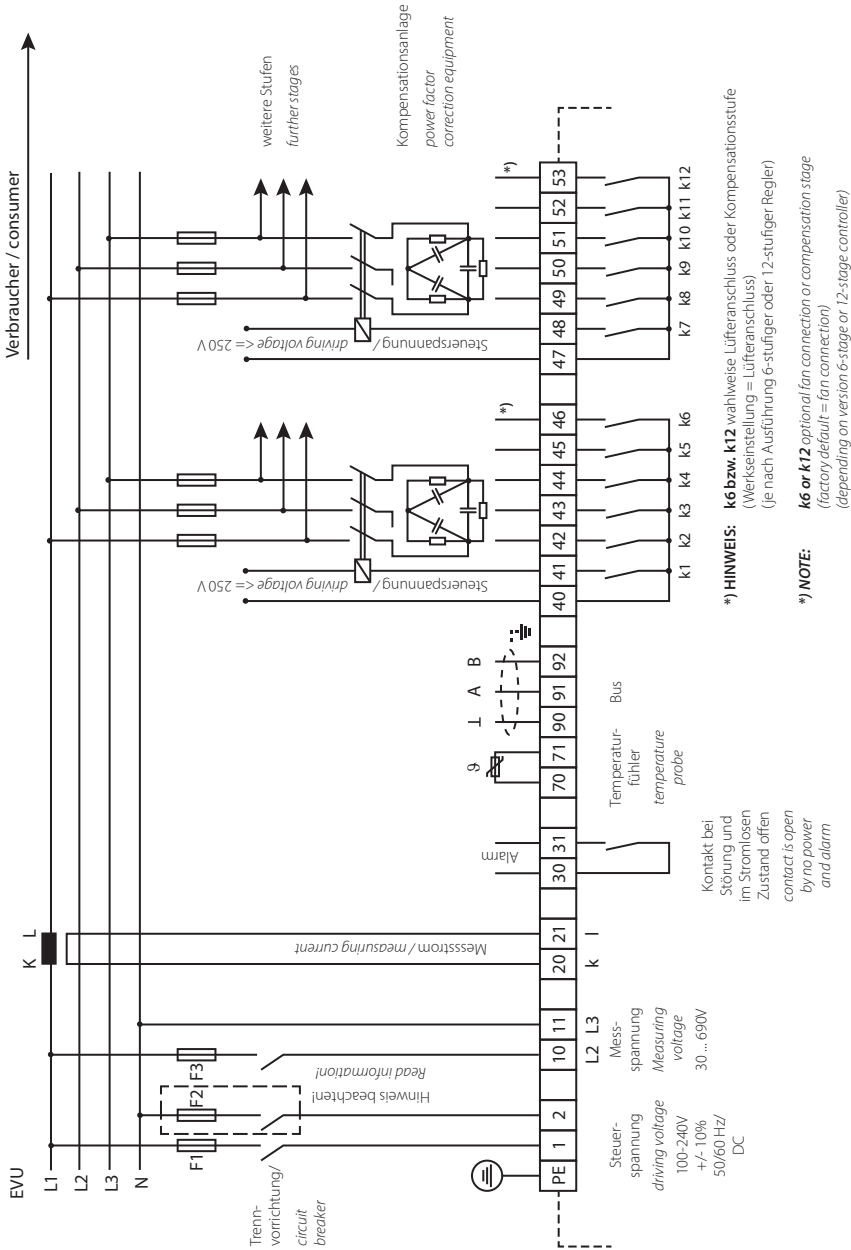

5.6 Measuring voltage connection Ph-Ph

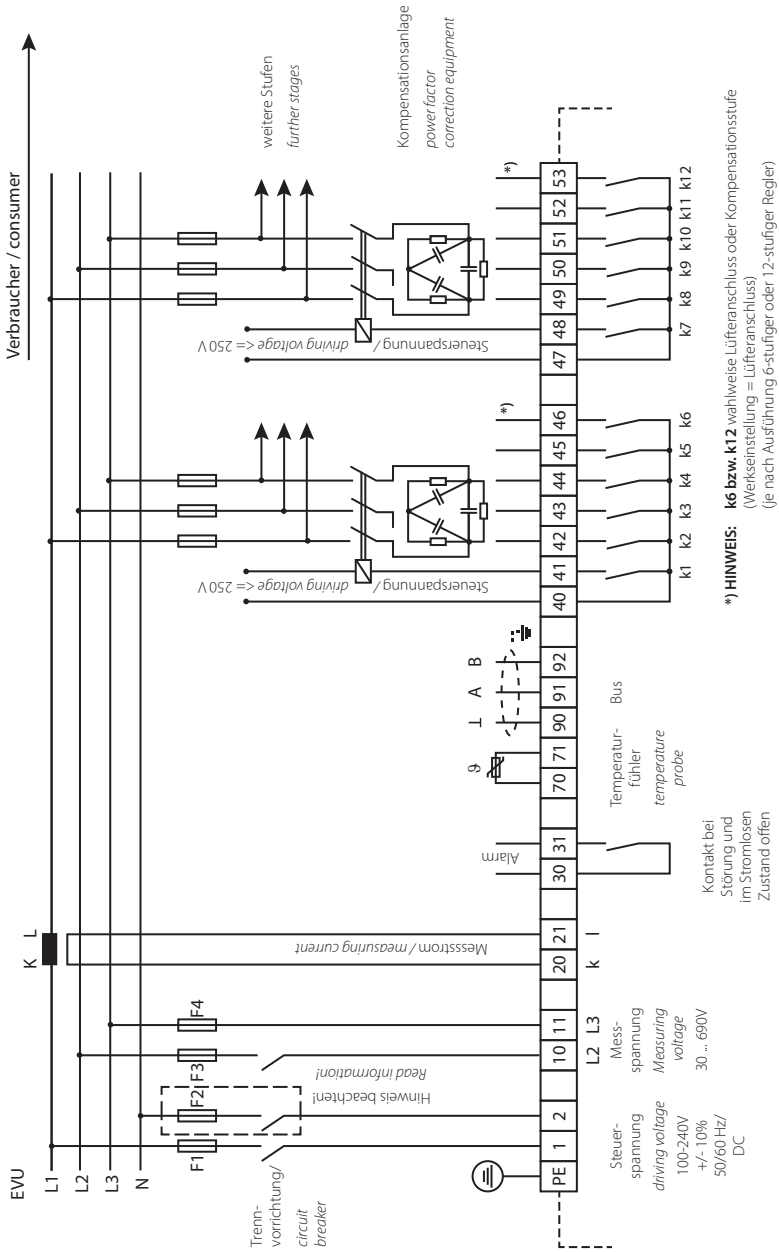

*) HINWEIS: k6 bzw. k12 wahlweise Lüfteranschluss oder Kompensationsstufe (Werkseinstellung = Lüfteranschluss) (je nach Ausführung 6-stufiger oder 12-stufiger Regler)

*) NOTE: k6 or k12 optional fan connection or compensation stage (factory default = fan connection) (depending on version 6-stage or 12-stage controller)

Kontakt bei Störung und im Stromlosen Zustand offen
contact is open by no power and alarm

6 Commissioning the System

6.1 General notes on commissioning

Compensation unit with controller

The controller is configured as a compensation system component (see connection diagram) by default. The following settings need to be configured or checked:

- Target cos phi according to electricity supplier specifications.
- Primary and secondary current in the main circuit according to the transformer fitted.
- If required, set the measuring voltage transformer data.
- If no stage powers have been programmed, the controller will switch to the Commissioning menu after initialization. Next, stage power programming can be performed in the settings menu, or using the learning process.



NOTE

You can start the learning process from the "Learning mode activate" submenu in the Commissioning menu, using the Enter/Input buttons.

If the "Learning mode" window is not displayed, please check the following:

- is Menu on set for "Learning mode" in the "Extras" menu?

The settings are saved on an EEPROM so that they are not lost in the event of a power failure.

- Switch on a sufficient number of inductive consumers (e.g. motors) before switching the compensation system on. A transformer current of at least 15 mA needs to be flowing in the secondary circuit for the controller to be activated. Below this limit, the error message "No transformer current" will be displayed.

Check the transformer connection (is the transformer ratio too high?).

- If all connection conditions are OK, the instantaneous power factor cos phi should be displayed after initialization, e.g. Normally, when no capacitors are connected, cos phi lies in the range of 0.6 to 0.9 inductive, (e.g. cos phi 0.80 ind).

- If a capacitive value is displayed, or if the "G" symbol is flashing, the phase allocation of the current and voltage measurement is incorrect. In the Commissioning programming menu, the phase allocation can be changed using the functions Rot. field U and Rot. field I (provided that there is no generator in operation at the time).
- The first switching operation may take up to 180 seconds. The stages are switched in set intervals until compensation occurs. The displayed cos phi must increase to at least the set target cos phi.

7 Navigation and Device Displays

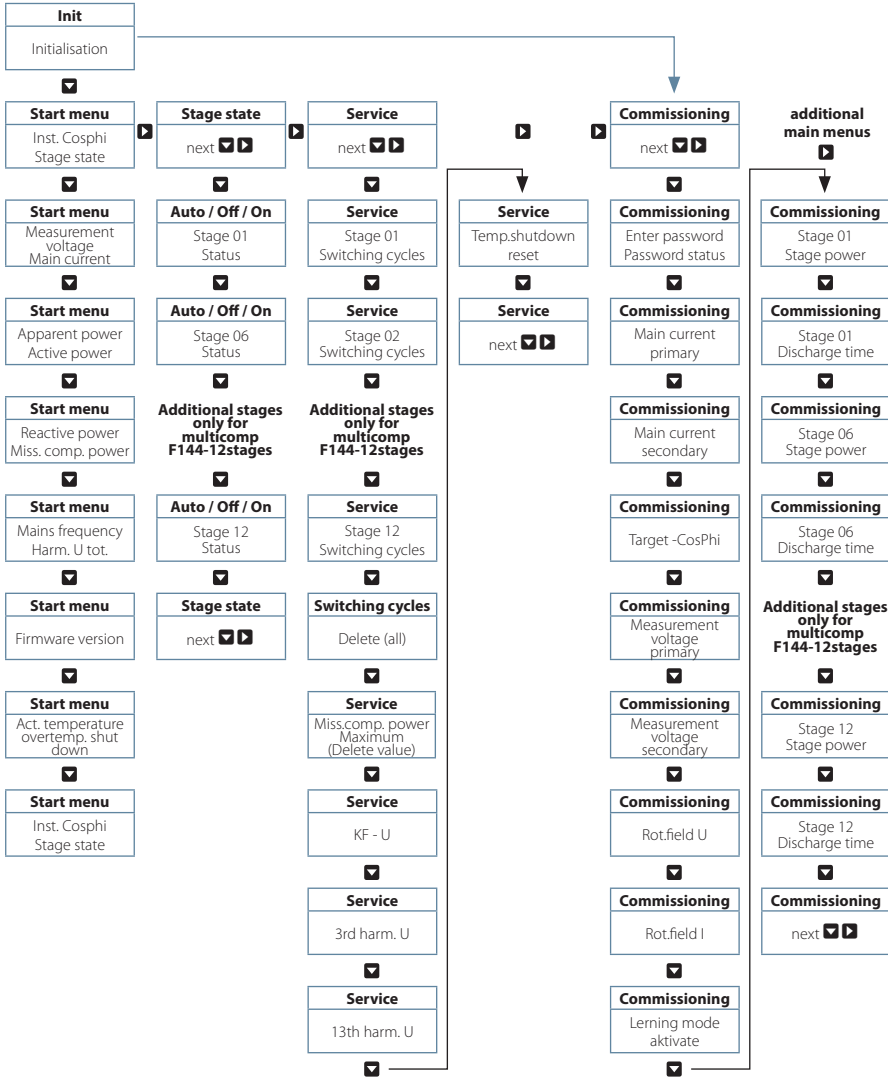

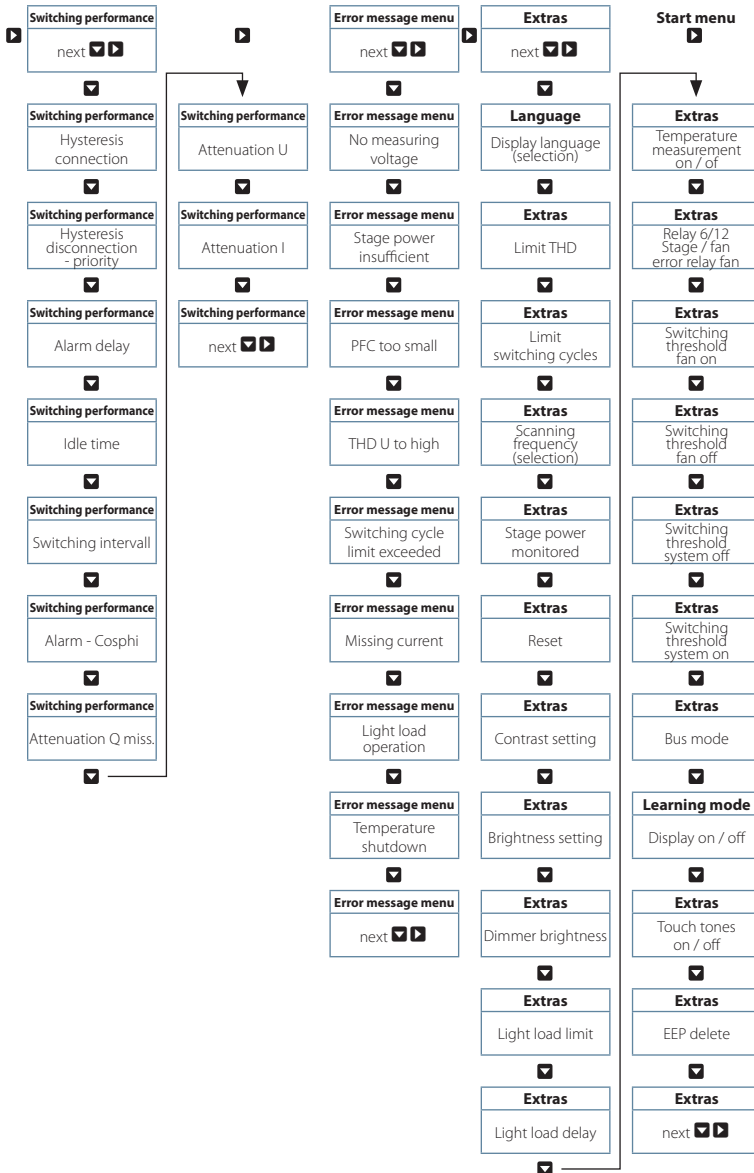

8 Device displays of the main menus

The following main menus and submenus can be used for current displays and controller configuration:

Initialization window – no input possible

multicomp F144-3 eco 6-stage or 12-stage

```
multicomp 06 eco  
Initialization
```

```
multicomp 12 eco  
Initialization
```

Start menu window – display of the current values

multicomp F144-3 eco 6-stage

```
cos $\psi$  0.71 IND  
AAAAAA
```

multicomp F144-3 Eco 12-stage

```
cos $\psi$  0.71 IND  
AAAAAAAAAAAA
```

Stage state window – stage status can be changed

```
Stage state  
next +→
```

Service window – display and deletion options

```
Service
next ↔
```

Commissioning window – entry of operating parameters

```
Commissioning
next ↔
```

Switching performance window – influencing switching performance

```
Switching
Performance
next ↔
```

Error message menu – editing the error message dialog

```
Message emenu
next ↔
```

Extras window – setting special parameters

```
Extras
next ↔
```

9 Description of the individual display windows

9.1. Initialization window:

multicomp F144-3 Eco 6-stage



multicomp F144-3 Eco 12-stage

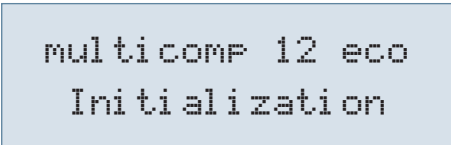

This is displayed after connecting the power supply to the controller.



NOTE

Please do not press any sensor buttons during initialization, as they are adjusted automatically to ensure correct operation.

9.2 Commissioning window if no stage power is programmed

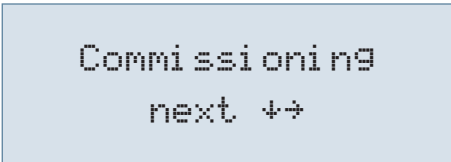

During initial startup of the multicomp F144-3 eco, the Commissioning menu is displayed as the F144-3 eco start screen (after the initialization phase) once you have connected the power supply.

This menu is used for initial startup of the controller, where all necessary settings can be made.

If a controller already integrated into a KBR compensation unit by default should be used, only the parameters of the current transformer have to be configured.

Press  to select submenus.



Password protection (parameter protection):

A password (a 4-digit numerical code, e.g. 4321) can be used to protect a system against unauthorized access to the configured parameters.

If the password should get lost, the controller can be unlocked with the master password 1976. To unlock a controller completely, enter the password 9999 (no password = 9999, all functions are accessible).

Password protection is not active until a waiting time of 300 seconds has elapsed without pressing any buttons.

After unlocking a password protected controller, it is possible to press a button for up to 300 seconds. If no buttons are pressed during this time, the controller is then locked again.

The password can be set or changed by pressing  to start entering or to change the entry position,  to change or set the password and  to save the entry.

Configuring current transformer values:

All current transformer parameters need to be configured correctly for the compensation controller to function properly. The primary and secondary current of the transformer need to be set (submenu Iprim. / Isec.). These parameters can be found on the nameplate of the current transformer. In addition, the phase allocation of the transformer needs to be configured correctly. This means that the phase (L1, L2, L3) which the current transformer is integrated in has to be set (submenu Rot. field I) in the controller. If the transformer connections are mixed up (k and l interchanged), this can be corrected with the setting -L1, -L2 and -L3.

Setting target cosine:

You can ask your electricity supplier for the target cos, which should be set up at this point. By default, the target cos is set to 0.95 inductive (see the "Default settings" chapter).

Setting the voltage transformer parameters:

Specify the primary voltage in the U primary submenu, the secondary voltage under U secondary and the phase allocation of the measuring voltage under Rot.field U. These settings apply to a standard network (voltage Ph-Ph: 400 V primary, 400 V secondary). If you use a voltage transformer, configure the parameters indicated on the voltage transformer, e.g. 690V / 100V, as well as the measuring mode, e.g. L12 for measuring voltage connection between phases L1 and L2.



NOTE

A voltage transformer must be used here with no phase shift between current and voltage, as the device is not able to compensate this.

Setting the discharge time:

Checking or, if necessary, changing the discharge time of the capacitor stages is a very important menu item. You can set the discharge time from 0 to 999 sec. Please make sure that the correct value is set, otherwise the capacitors could be damaged.

Configuring the capacitor stages:

There are two ways of configuring the capacitor stages. The stages can be configured manually or using the auto configuration mode.





NOTE

The Auto configuration mode menu will not appear if the "Learning mode" is deactivated in the "Extras" menu

It is important to set the stage power correctly. You can find the stage power on the nameplate of the stage or the circuit diagram and then program it manually. In this case, skip the menu item "Learning mode activate" and enter the power value individually for each stage.

If you want to activate the learning mode, you have to make sure that all previous sub-menu parameters have been set correctly.

To activate learning mode, press , change the setting to Yes by pressing , then press  to confirm.

The auto configuration then automatically sets the stage powers and discharge times, but these values need to be checked once the learning process has been completed to ensure that they are correct.



NOTE

If an error occurs in auto configuration mode (harmonics exceeding the limit, measuring voltage too high, missing measuring voltage), the process is interrupted and "Auto configuration mode – Error" is displayed. Auto configuration mode can be restarted once the cause of the error has been rectified.

System function test:

A function test should be performed after all values have been programmed step by step, by disconnecting the controller from the power supply for a few seconds.

The controller should start automatically after it is reconnected to the power supply. If the $\cos\phi$ voltage is read in the start menu immediately after switching it on, the value for $\cos\phi$ should be low and inductive. After approx. 60 seconds, the controller starts to switch on the individual capacitor stages.

The $\cos\phi$, which can be read in the start menu, should have risen in comparison to its previous value, or it should rise when additional stages are switched on. If the compensation system is designed correctly, the controller should compensate to the set target $\cos\phi$ after a while.

9.3 Start menu window:

Example: F144-3 Eco 12-stage

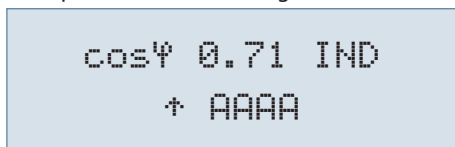

This is displayed after the initialization window if the stage power has already been programmed. The current total controller state and the currently measured CosPhi are measured here.

Example:

Line 1: currently measured CosPhi 0.71 inductive

Line 2: the controller switches on stages; stages 1 to 4 are already switched to automatic operation, where:

| | |
|---|---|
| ↑ | stages are switched on as compensation power is required. |
| ↓ | stages are switched off due to overcompensation. |
| A | the stage has been switched to automatic mode. |
| a | the stage has been switched off by the automatic mode. |
| M | the stage has been switched on manually |
| m | the stage has been switched off manually. |
| X | the stage's measured stage power does not correspond to the configured value (stage monitoring activated, p. the Stage monitoring submenu of the Extras menu) |

**NOTE**

It is similar for the alarm relay or fan relay status display. Explanation:

| | |
|----------|--|
| E | the error message is active, the relay is open (there is an error) |
| e | the error message is not active, the relay is closed (there is no error) |
| V | the fan relay is active (the relay is closed, the fan turn-on threshold was or is exceeded or the run-on-time has not elapsed yet) |
| v | the fan relay is not active (the relay is open, the fan turn-on threshold is not exceeded or the run-on-time has elapsed) |

Press  to select submenus.

The current readings are displayed in the submenus:

Measuring voltage in volts depending on the selected connection type (Commissioning menu, Rot. field U submenu) in Ph-N (⚡) or Ph-Ph (⚡).

Main series transformer apparent current in amps (single-phase value).

Apparent power in kVA, projected as a 3-phase value (provided the network load is symmetrical).

Active power in kW, projected as a 3-phase value (provided the network load is symmetrical).

Reactive power in kvar, projected as a 3-phase value (provided the network load is symmetrical).

Compensation power to achieve the set target cos phi missing.

The missing compensation power is displayed up to a maximum value of 9999.9 kvar. If the value exceeds this limit, 9999.9 kvar is displayed

Power frequency in Hz

THD (Harm. U total) in %, decisive for setting the THD limit (Extras menu, THD limit submenu)

Current temperature reading (if temperature measurement is activated; --- °C is displayed if measurement is deactivated)

Number of overtemperature switch-offs (if temperature measurement is activated; --- °C is displayed if measurement is deactivated)

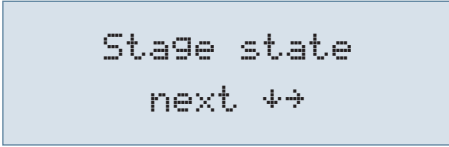

It is important to know the firmware version of the controller, e.g. V 2.00R001 for support requests, as it can be used to deduce possible changes made to the device firmware.

9.4 Stage state window:



Press  to select submenus.

The submenus in this window display whether or not the capacitor stages connected are working in automatic mode, or if they are switched on or off permanently. The individual capacitor stages can be selected by pressing .

You can change the stage state from **Auto** (Automatic) to **Off** (switched off permanently) or **On** (switched on permanently) by pressing  to start entering values,  to make changes or  to save them.







NOTE

Capacitor stages that are permanently switched on or off are not available to calculate the optimizing automatic operation.



9.5 Service window:



Press  to select submenus.

The number of connections of each individual capacitor stage is displayed in the sub-menu of this window. This value can be erased individually for each level by pressing  and  together. You can delete the accumulated operating cycles for all stages by selecting “Delete operating cycles” and pressing  and  simultaneously.

If the number of operating cycles of a stage equals or exceeds the value set in the menu item Extras / Operating cycle limit, a message is displayed, depending on the Operating cycle limit exceeded setting in the Error message menu.

In addition, the value in the menu item Missing comp. power maximum can be deleted by pressing  and  simultaneously, resetting the Facility too small message. If the set target cos phi is not reached, despite all available stages being switched on, this message is displayed after the set alarm delay time has elapsed.

The alarm delay can be set in the Switching performance / Alarm delay menu .

You can also delete the number of overtemperature switch-offs here (this menu item is only displayed if temperature measurement is activated and accumulated switch-offs are displayed).

9.6 Commissioning window:

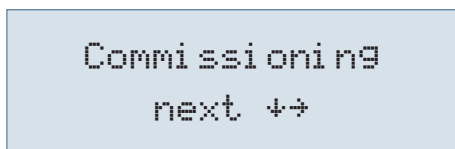

Press  to select submenus.



A step-by-step description of the setup process is given in the submenus of this window. For systems which are already running, the parameters configured during setup can be read out here.

Password protection:

A password (a 4-digit numerical code, e.g. 4321) can be used to protect a system against unauthorized access to the configured parameters.

If the password is lost, the controller can be unlocked using the **master password 1976**.

After unlocking a password protected controller, it is possible to press a button for up to 300 seconds. If no buttons are pressed during this time, the controller is then locked again.

The password can be set or changed by pressing  to start entering or to change the entry position,  to change or set the password and  to save the entry.

Configuring current transformer values:

All current transformer parameters need to be configured correctly for the compensation controller to function properly. The primary and secondary current of the transformer have to be set (**submenu Iprim. / Isec.**). These parameters can be found on the nameplate of the current transformer. In addition, the phase allocation of the transformer needs to be configured correctly. In the controller, the phase (L1, L2, L3) in which the current transformer is integrated has to be set (**Rot. field I submenu**). If the transformer connections are mixed up (k and l interchanged), this can be corrected with the setting -L1, -L2 and -L3.



CAUTION

Changing the main current transformer parameters or voltage transformer values subsequently can directly influence the capacitor stages for which the stage power was determined using the auto configuration mode. This ensures that the stage power is adequately adjusted in case of a subsequent correction of the transformer parameters.

Manually configured stages are not taken into account here.

Setting target cosine:

You can ask your electricity supplier for the target cos, which should be set up at this point. By default, the target cos is set to 0.95 inductive (see the "Default settings" chapter).

Setting the voltage transformer parameters:

Specify the primary voltage in the U primary submenu, the secondary voltage under U secondary and the phase allocation of the measuring voltage under Rot.field U. These settings apply to a standard network (voltage Ph-Ph: 400 V primary, 400 V secondary). If you use a voltage transformer, configure the parameters indicated on the voltage transformer, e.g. 690V / 100V, as well as the measuring mode, e.g. L12 for measuring voltage connection between phases L1 and L2.

Setting the discharge time:

Checking or, if necessary, changing the discharge time of the capacitor stages is a very important menu item. You can set the discharge time from 0 to 999 sec. Please make sure that the correct value is set, otherwise the capacitors could be damaged.

Configuring the capacitor stages:

There are two ways of configuring the capacitor stages. The stages can be configured manually or using the auto configuration mode.

It is important to set the stage power correctly. You can find the stage power on the nameplate of the stage or the circuit diagram and then program it manually. In this case, skip the menu item "Learning mode activate" and enter the power value individually for each stage.



NOTE

If you cannot select the Learning mode menu item, check whether menu "On" is selected for "Learning mode" in the "Extras" menu.

If you want to **activate the learning mode**, make sure that **all previous submenu parameters** have been set correctly.

The learning mode is activated by pressing . Change to **Yes** by pressing and then to confirm.

After starting the learning mode, **act.i** we flashes and the remaining time until the end of the learning mode is displayed.

The auto configuration then sets the stage power automatically, However, this value has to be checked each time the learning process is completed.

9.7 Switching performance window:

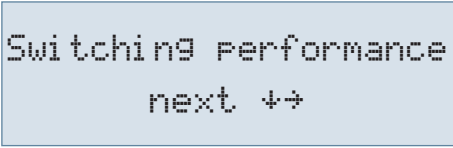

Switching Performance
next \leftrightarrow

Press  to select submenus.

The default switching performance settings (default settings) are displayed in the sub-menu of this window. These settings apply to most compensation systems.



NOTE

Check all parameters to ensure that they do not deviate from the specifications for this system.

The following submenus are available to affect switching performance:

- Hysteresis connection (default setting 100%, setting range 70 to 150 %): This value defines the controller switch-on criterion. This means the controller would switch on at 100% missing compensation power relative to the smallest capacitor stage of the system.
- Hysteresis switch-off (default setting 100%, setting range 70 to 150 %): This value defines the controller switch-off criterion. This means the controller would switch off at 100% overcompensation power relative to the smallest capacitor stage of the system.
- Priority allows the switching criteria for the compensation stages to be changed. This setting indicates that the compensation stages should be used as evenly as possible. It allows the compensation stages to be selected according to the fewest operating hours (turn-on duration) or the fewest switching cycles.
- With the setting for the fewest operating hours, an exchange of the connected compensation stages with equivalent stages after 24 hours of run-time can also be activated/deactivated with the parameter \uparrow 24h \leftrightarrow
- Alarm delay (default setting 1200 seconds, setting range 0 to 3000 seconds): This value defines the time until the message **Compensation unit too small** is displayed. If the set target cos phi is not reached, despite all available stages being switched on, this message is displayed after the set alarm delay time has elapsed.
- Idle time (default setting 30 seconds, setting range 0 to 300 seconds): This value defines the time the controller is idle **after compensation** before another switching operation is performed (connection or disconnection).

Description of the display window

- Switching interval (default setting 8 seconds, setting range 0 to 10 seconds):
This value defines the time the controller is idle between two switching operations.
- Alarm cos phi (default setting ind. 0.92, setting range ind. 0.70 to 1.0):
This value is connected to the message Facility too small. If this value is not reached after the alarm delay has elapsed, despite all stages being switched on, the message PFC too small is displayed.
- Attenuation Qmiss (default settings 2, setting range 0 to 9):
This value defines the attenuation of the display and control behavior to prevent rapid parameter changes if there is no compensation power.
- Attenuation U (default setting 0, setting range 0 to 9):
This value defines the display attenuation to prevent rapid parameter changes of the measuring voltage.
- Attenuation I (default setting 2, setting range 0 to 9):
This value defines the display attenuation to prevent rapid parameter changes of the measuring current.

9.8 Error message window:

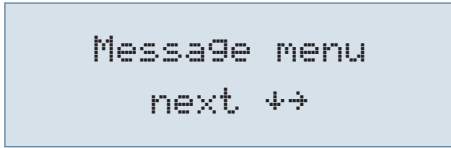





Press  to select submenus.

The possible messages and the display configuration are displayed in the submenus of this window.

The following error messages can be configured:

| Alarm submenu | Possible actions | | | |
|---|------------------|---------|-------------|-------------------|
| | Off | Message | Alarm relay | Message and relay |
| No measuring voltage | ✓ | ✓ | ✓ | ✓ |
| No stage power | ✓ | ✓ | ✓ | ✓ |
| PFC too small | ✓ | ✓ | ✓ | ✓ |
| THD (voltage harmonics) too high | ✓ | ✓ | ✓ | ✓ |
| Operating cycle limit exceeded (contactor stages) | ✓ | ✓ | ✓ | ✓ |
| No measuring current | ✓ | ✓ | ✓ | ✓ |
| Light load operation | ✓ | ✓ | ✓ | ✓ |
| Temperature switch-off | ✓ | ✓ | ✓ | ✓ |

If a submenu is selected (by pressing ), the error message dialog can be changed by pressing  to start entering values,  to change the settings and  to save them.



NOTE

The stage monitoring function (see Extras menu, Stage power monitored submenu) does not generate any messages, but marks the stages with an **X** (in the Start menu window).

9.9 Extras window:

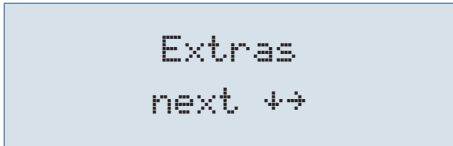



Press to select submenus.

The additional possible settings are displayed in the submenu of this window:

If a submenu is selected (by pressing), the settings can be changed by pressing to start entering values, to change the setting and to save it.

The following submenus are available:

- **User language:**
In this submenu, you can select the language for the LCD display (German, English, French or Spanish).
- **Limit THD:**
The harmonic switch-off limit refers to the total of all measuring voltage harmonics (Lim THD). The programming range is between 0 and 10%. The setting can be adjusted in increments of 1 %.
In addition, harmonics monitoring can also be disabled here (limit monitoring is deactivated if the setting is Lim = 0%).
If voltage harmonics exceed the limit, an error message is displayed and a stage switch-off is performed.
- **Operating cycle limit:**
The limit of the capacitor contactor operating cycles is used as an indication to customers that the capacitor contactor could be worn out due to the number of switching operations accumulated. This message in no way influences the function of the compensation system. It is merely used as a "maintenance instruction". If the setting is Lim = 0%, limit monitoring is deactivated but the operating cycle count is still activated.

- **Sampling rate:**
The power frequency tracing settings are displayed in this submenu. The setting "Auto" causes the sampling rate to be traced automatically, within a range of 40 to 70 Hertz. Alternatively, a fixed sampling rate of **50 Hz** or **60 Hz** can be set.
- **Stage power monitored:**
Monitoring of the stage power can be activated or deactivated in this submenu. Only stages the stage power of which has been recorded in the learning mode are monitored.
The manually configured stage power is not taken into account, as it is assumed that the stage power has been configured in accordance with the nameplate of the compensation stage.
- **Functional principle:**
Each time a capacitor stage is switched on, a check is performed to determine whether a change of current takes place in the main current transformer. If this is not the case, the stage is marked with an **X** in the start menu window. This may be for one of the following reasons and needs to be checked:
 - Capacitor faulty
 - Contactor faulty
 - Fuse faulty
- **Reset:**
The Reset menu item offers various methods of resetting the programmed controller parameters. The programmable parameters are reset to the default settings. This has the advantage that all configured parameters are deleted at the same time and the controller restarts with the default settings.
- **Perform reset:**
Extras menu, Reset menu item
Press  = Reset flashes
Press  and  simultaneously = **done** is displayed
After about 2 seconds, **Reset** is displayed again



NOTE

The reset process can be interrupted by pressing .

- **Contrast setting:**
The contrast settings of the LCD can be changed in this submenu.
Setting range: 0 to 10.

Description of the display window

- **Brightness setting:**
The LCD brightness can be changed in this submenu. Setting range: 0 to 9.
- **Dimmer brightness:**
The LCD dimming can be changed in this submenu. Setting range: 0 to 9. The brightness is reduced after a set time of 15 minutes.
- **Low load limit:**
In this submenu, the light load detection limit can be changed to either 15 mA or 50 mA.
- **Low load delay:**
The low-load detection delay time of the stage switch-off can be changed in this submenu. It can be varied between 1 and 60 minutes.
- **Temperature measurement:**
In this submenu, the temperature measurement can be activated or deactivated.
- **Fan relay:**
In this submenu, the fan relay can set the last stage relay (stage 6 or 12, depending on the device version) or assign the alarm relay.
- **Switching threshold fan on:**
In this submenu, the switching threshold for switching on the fan relay can be changed to between 0°C and 70 °C.
- **Switching threshold for switching off fan:**
In this submenu, the switching threshold for switching the fan relay off can be changed to between 0°C and 70 °C. **To prevent unnecessary fan switching, a run-on time of 30 minutes is set.**
- **Switching threshold for system switch-off:**
In this submenu, the switching threshold for switching off the system can be changed to between 0°C and 70 °C.
- **Switching threshold for system switch-on:**
In this submenu, the switching threshold for switching on the system can be changed to between 0°C and 70 °C.

- **Bus mode:**
In this submenu, the bus protocol of the device can be set. to KBR eBus or Modbus RTU. If Modbus RTU is selected, you can set the transmission parameters now. The supported transmission parameters are:
 - Baud rate (Baud) 4800, 9600, 19200, 38400
 - Parity even, odd, none
 - Data bits 8
 - Stop bits 1 for even and odd, 2 for Parity noneThe KBR eBus setting is used for testing purposes.
- **Learning mode:**
In this submenu, you can show or hide the submenu item "Activate learning mode" (in the Commissioning menu).
- **Key sounds:**
In this submenu, you can turn the key sounds (which sound if a sensor button is pushed) on or off.
- **Delete EEPROM:**
For production purposes only.

10 Notes on Troubleshooting

Undercompensation, not enough stages are switched on:

Check controller for error messages If the target $\cos \varphi$ is set to 0.8 capacitive, the capacitors need to start being switched on. If the system is not over-dimensioned, almost all stages need to be switched on.

Check the system's main fuse and group fuses. All values can be found in the enclosed documents.

The group fuses must display at least 1.7 times the value of the capacitor power.

If the fuses blow despite being correctly selected, the groups must be checked individually for excessive current input and defective contactors.

Undercompensation, all stages are switched on:

The existing system is insufficiently dimensioned (e.g. due to new inductive consumers). Please contact your local representative (enlarge your system). The number of the service hotline is given on the cover of these operating instructions.

Overcompensation, too many stages are switched on:

Check the controller settings (target $\cos \varphi$ capacitive?).
Is the transformer installed in the wrong position?

Controller switches too often, in particular during light load times (at the weekend, at night):

Check the transformer ratio configuration. If necessary, (manually) switch a small stage on permanently.



NOTE

Please call your local representative if you are unable to find the cause of the error.

11 System and Safety Device Maintenance

In order to ensure that your system functions properly and has a long service life, perform the following checks after commissioning and then on an annual basis.

- Check and re-tighten all connections. Screw connections may become loose at the beginning due to thermal stress.
- Check fuses, safety devices and switching equipment. Contactors are wearing parts. If the contactor is intact, switching must take place without excessive formation of sparks.
- Check the control performance in automatic mode.
- Check the cooling air setting (fans, temperature monitoring function):
- Check that the controller temperature relay switches the fans on at 28 °C.
- Check that the temperature monitoring switches the system off via controller at 48 °C.
- Clean the filter mats if necessary, depending on how dirty they are.
- Perform a visual inspection of the capacitors.
- Examine the current input and capacitor terminal voltage once every three months.
- Check the reactive energy consumption on the basis of the electricity bill.



NOTE

The current consumption and the temperature of these systems must be checked regularly so that overloading of the capacitors can be detected at an early stage. Excessive current consumption can be caused by an increasing proportion of harmonics or by faulty capacitors.

12 Technical Data

12.1 Measuring and display values

| | | |
|----------------------------|-------------------------------------|--|
| Voltage | RMS value of a measuring interval | Phase - 0 or phase - phase, depending on configuration |
| | Units | V, kV;] display switches automatically |
| | Display range | 0.00 kV to 99.9 kV |
| | Measuring range | 30 - 690 VAC (max. permissible value: 790 VAC) |
| Current (apparent current) | RMS value of a measuring interval | Actual value per phase |
| | Units | [A; kA] display is switched automatically |
| | Display range | 0.00 A to 999 kA |
| | Measuring range | 0.015 - 5 A (max. permissible value: 6 A) |
| Frequency | Network frequency measurement | f_{Network} |
| | Units | [Hz] |
| | Measuring range | 41 - 70 Hz |
| Apparent power | Calculation | S_{tot} ; 3-phase |
| | Units | kVA |
| | Display range | 0.0 VA to 9999.9 kVA |
| Active power | Calculation | P_{total} ; 3-phase |
| | Units | kW |
| | Display range | 0.0 W to 9999.9 kW |
| Reactive power | Calculation —> ind. and cap. | Q_{total} ; Q_{miss} ; distinction between ind./cap. |
| | Units | kvar |
| | Display range | 0.0 var to 9999.9 kvar |
| Power factor | Calculation —> ind. and cap. | CosPhi; distinction between ind./cap. CosPhi in display |
| | Display range | CosPhi 0.10 ind. <—1 —>0.10 cap. |
| Temperature | Measuring range | -10°C to +60°C |
| Harmonics | Distortion factor (THD) for voltage | Voltage: THD-U |
| | Partial distortion factors | 3 rd , 5 th , 7 th , 9 th , 11 th , 13 th ; voltage harmonic |
| | Units | [%] |
| | Measuring range | 0.00% to 100% |

12.2 Measuring accuracy

| | |
|--------------|---|
| Current | $\pm 0.5\% / \pm 1$ digit (for 0.1 to 5 A) |
| Voltage | $\pm 0.5\% / \pm 1$ digit |
| Power | $\pm 1\% / \pm 1$ digit |
| Power factor | $\pm 1\% / \pm 1$ digit |
| Frequency | $\pm 0.1\% / \pm 1$ digit |
| Temperature | $\pm 2\text{ }^\circ\text{C} / \pm 1$ digit |

12.3 Measuring principle

| | |
|--|---|
| Sampling | 128 readings per period |
| A/D converter | 12 bit |
| Measurement of U and I | Simultaneous recording of U and I readings; |
| Update speed (complete measuring cycle) | 20 ms |
| Harmonics calculation | FFT with 128 points over one period |
| Frequency measurement | Consumption: Voltage measurement between phase Lx - N / Ly) |
| Temperature sensor | Analog measurement with PT 1000 |

12.4 Device memory

| | |
|------------------------------|----------------------------------|
| Memory | 16 kB RAM (volatile) |
| Program and parameter memory | 128 kB flash |
| Extreme values (max.) | No compensation power Q_{\max} |
| Operating cycles | Memory cycles every 15 minutes |
| Temperature | max. measured value |

12.5 Limits:

| | |
|--------------------------|---|
| Limit violations: | |
| Harmonics | Acquisition time approx. 100 ms |
| Overvoltage switch-off: | Acquisition time approx. 40 ms |
| Zero-voltage switch-off: | Acquisition time approx. 40 ms (for measuring voltage) |

12.6 Power supply

| | |
|--------------|---|
| Power supply | 100V - 240V +/-10% DC/50/60 Hz 12VA, 6W |
|--------------|---|

12.7 Hardware inputs and outputs

12.7.1 Hardware inputs

| | | |
|-------------------------|----------------------------------|---|
| Voltage measuring input | U_{PH-N} or U_{PH-PH} | 30 - 690 VAC (max. permissible value: 790 VAC) |
| | Input impedance | 1500 kOhm |
| | Measuring range | 1 measuring range, measuring voltage transformer can be programmed |
| Current measuring input | I_{L1} or I_{L2} or I_{L3} | 0.015 - 5 A (max. permissible value: 6 A) |
| | Power consumption | 0.3 VA at 6 A, 0.05 VA at 1.2 A |
| | Measuring range | 1 measuring range, current transformer can be programmed |
| Analog input | PT 1000 measurement sensor | Temperature measurement -10 °C to 60 °C, +/- 2 °C max. cable length < 3 meters |

12.7.2 Hardware outputs

| | | |
|-----------------------|---------------------|--|
| Alarm relay | Switching capacity | 250 V (AC) / 2 A floating |
| Capacitor stage relay | Switching capacity | 250 V (AC) / 2 A floating |
| Serial interface | BUS | RS485 for connection to the Modbus |
| | Protocol, baud rate | Modbus RTU, bud rate 4800, 9600, 19200, 38400 Parity none, even, odd |
| | Address assignment | Modbus: manual setting on the device, address 1 to 247 |

12.8 Electrical connection

| | | |
|---|------------------------------------|--|
| Connection elements | | Plug-in terminals |
| Permissible cross-section of the connection lines | | 2.5 mm ² |
| Measurement voltage inputs | Fuse | max. 1 A slow blow or max. C2 - automatic in addition isolating switch UL/IEC-approved |
| Measuring current input | Fuse | NONE!!! Always short-circuit current transformer terminals k and l before opening the circuit! |
| Input control voltage | Fuse | max. 1 A slow blow or max. C2 - automatic in addition isolating switch UL/IEC-approved |
| BUS connection | Connection material | To ensure proper operation, only use shielded twisted-pair cables; e.g. I-Y(St)Y EIB 2x2x0.8 |
| Relay output | Fuse | max 2 A medium time-lag |
| Transformer connection | Connections | See connection diagram |
| Interface connection | Pins for BUS connection via RS-485 | Terminal 90 ⊥ Terminal 91 A Terminal 92 B |

12.9 Mechanical data

| | | |
|--------------------------|----------------------|--------------------------------|
| Switchboard installation | Housing dimensions | 144 x 144 x 60 mm (H x W x D), |
| | Installation cut-out | 138 x 138 mm |
| | Weight | Approx. 650g |

11.10 Standards and miscellaneous

| | | |
|--------------------|--|--|
| Ambient conditions | Standards | DIN EN 60721-3-3:1995-09 + DIN EN 60721-3-3/A2:1997-07; 3K5+3Z11; (IEC721-3-3;3K5+3Z11) |
| | Operating temperature | K55/ -5 °C +55°C |
| | Air humidity | K55 / 5% 95% non-condensing |
| | Storage temperature | -25°C+70°C |
| | Operating height | up to max. 2000 m above sea level |
| Electrical safety | Standards | DIN EN 61010-1:2011-07; DIN EN 61010-2-030:2011-07 |
| | Protection class | I |
| | Overvoltage category, measurement category | voltage measurement CAT III: 400 V current measurement CAT III: 300V power supply CAT III: 300V |
| Protection type | Standards | DIN EN 60529:2014-09 |
| | Front | IP 51 (with optional front door max. IP 54) |
| | Terminals | IP 20 |
| EMC | Standards | DIN EN 61000-6-2:2006-03 + amendment 1:2011-06 DIN EN 61000-6-3:2011-09 + amendment 1:2012-11 |
| | Rated surge voltage | 4 kV |

12 Selection of cables and fuses

| C power (400 V) Q (kvar) | Current consumption I (A) per phase | Supply cable Cu (mm ²) | Fuse (slow-blow) 3 x I (A) |
|-----------------------------|---|---------------------------------------|-------------------------------|
| 0.5 | 0.72 | 4 x 1.5 | 10 |
| 1 | 1.44 | 4 x 1.5 | 10 |
| 1.5 | 2.16 | 4 x 1.5 | 10 |
| 2 | 2.88 | 4 x 1.5 | 10 |
| 2.5 | 3.60 | 4 x 1.5 | 10 |
| 3 | 4.32 | 4 x 1.5 | 10 |
| 4 | 5.76 | 4 x 1.5 | 10 |
| 5 | 7.20 | 4 x 2.5 | 16 |
| 6 | 8.64 | 4 x 2.5 | 16 |
| 7.5 | 10.80 | 4 x 2.5 | 16 |
| 10 | 14.40 | 4 x 2.5 | 25 |
| 12.5 | 18.00 | 4 x 6 | 35 |
| 15 | 21.60 | 4 x 10 | 35 |
| 16.7 | 24.00 | 4 x 10 | 35 |
| 20 | 28.80 | 4 x 10 | 50 |
| 25 | 36.00 | 4 x 16 | 63 |
| 30 | 43.20 | 4 x 16 | 80 |
| 33.3 | 48.00 | 4 x 16 | 80 |
| 35 | 50.40 | 4 x 25 | 80 |
| 40 | 57.60 | 4 x 25 | 100 |
| 45 | 64.80 | 3 x 35/16 | 100 |
| 50 | 72.00 | 3 x 50/25 | 125 |
| 60 | 86.40 | 3 x 50/25 | 125 |
| 70 | 100.80 | 3 x 70/35 | 160 |
| 75 | 108.00 | 3 x 70/35 | 160 |
| 80 | 115.10 | 3 x 95/50 | 200 |
| 90 | 129.60 | 3 x 95/50 | 200 |
| 100 | 144.00 | 3 x 95/50 | 250 |
| 120 | 172.80 | 3 x 120/70 | 250 |
| 125 | 180.00 | 3 x 120/70 | 250 |
| 150 | 216.00 | 3 x 150/70 | 315 |
| 180 | 259.20 | 3 x 240/120 | 400 |
| 200 | 288.00 | 3 x 240/120 | 400 |
| 250 | 360.00 | 2 x 3 x 150/70 | 500 |
| 300 | 432.00 | 2 x 3 x 185/95 | 630 |
| 350 | 504.00 | 2 x 3 x 240/120 | 2 x 400 |
| 400 | 576.00 | 2 x 3 x 240/120 | 2 x 400 |
| 450 | 648.00 | 4 x 3 x 120/70 | 2 x 500 |
| 500 | 720.00 | 4 x 3 x 150/70 | 2 x 500 |

14 Data Point Description for the Modbus Protocol

multicom F144-3

- 14.1 Modbus commands supported
- 14.2 Data formats
- 14.3 Interface parameters
- 14.4 Device settings
- 14.5 Data points
- 14.6 Device information

14.1 Modbus commands supported

| | |
|------|----------------------------|
| 0x04 | Read Input Registers |
| 0x2B | Read Device Identification |

The multcomp F144-3 does not support broadcast commands. All Modbus commands described are device-specific commands.

14.2 Data formats

(unsigned) short: 0x1234

| | | | | |
|----------|------|------|--|--|
| Address | +0 | +1 | | |
| Contents | 0x12 | 0x34 | | |

Rule for byte sequence: MSB before LSB

(unsigned) long: 0x12345678

| | | | | |
|----------|------|------|------|------|
| Address | +0 | +1 | +2 | +3 |
| Contents | 0x12 | 0x34 | 0x56 | 0x78 |

Rule for byte sequence: MSB before LSB

float:

| | |
|----------------|---|
| Format | Complies with the IEEE 754 standard |
| Representation | 4 bytes |
| Accuracy | 24 bits (➤ represent >7 decimal points) |
| Composition | 24-bit mantissa; 8-bit exponent |
| Mantissa | 24 bits (M) + 1 bit (S) |
| Exponent | The MSB of the mantissa is always 1 => it is not saved separately! S = sign of the mantissa: S = 1 ➤ negative number; S = 0 ➤ positive number |
| Exponent | 8 bits (0-255); is saved relative to 127, i.e. the current value of the exponent is calculated by subtracting the number 127 from the saved value. Curr. exp. = saved exp value. - 127 => range from 128 to -127! |

Example 1: -12.5 decimal = 0xC1480000 hex

M: 24 bit-mantissa

E: Exponent with offset of 127

S: Sign for mantissa (S=1 neg.; S=0 pos.)

| Address | +0 | +1 | +2 | +3 |
|---------|-----------------|-----------------|-----------------|-----------------|
| Format | SEEEEEEE | EMMMMMMM | MMMMMMMM | MMMMMMMM |
| Binary | 1 1 0 0 0 0 0 1 | 0 1 0 0 1 0 0 0 | 0 0 0 0 0 0 0 0 | 0 0 0 0 0 0 0 0 |
| Hex | C1 | 48 | 00 | 00 |

The byte sequence is defined as follows:

The byte with the "S sign bit" is transmitted over the bus as the first byte.

The sequence of the float bytes of the bus can be reversed, if necessary, using the device parameter 0xD02C (see table 1).

The register value 0xD02C in this case means:

- with 1 -> sign bit S in 1st byte (sequence as defined)
- with 0 -> sign bit S in 4th byte (sequence reversed)

The following information can be derived from this:

The sign bit is 1 => negative mantissa

The value of the exponent amounts to 1000010 bin or 130 dec.

This results in an exponent value of: $130 - 127 = 3$

The mantissa has the following value: 1001000000000000000000

The decimal point can be found at the left end of the mantissa, preceded by a 1. This position does not appear in the hexadecimal numeric notation. If you add 1 and set the decimal point at the beginning of the mantissa, the following value is obtained:

1.1001000000000000000000

Now, the mantissa needs to be adjusted to the exponent. A negative exponent shifts the decimal point to the left, a positive exponent shifts it to the right. Since the exponent is 3, this is represented as: 1100.10000000000000000000

The number obtained corresponds to the binary floating-point number.

Binary digits to the left of the decimal point result in values > 1. In this example, 1100 bin results in the number 12 dec. $\{(1 \times 2^3) + (1 \times 2^2) + (0 \times 2^1) + (0 \times 2^0)\}$

Binary digits to the right of the decimal point result in values < 1. In this example, .100..... bin results in the number 0.5 dec. $\{(1 \times 2^{-1}) + (0 \times 2^{-2}) + (0 \times 2^{-3}) + (0 \times 2^{-4})\}$

By adding the individual values, 12.5 is obtained. As the sign bit was set, it is a negative value, -12.5. The hexadecimal number 0xC1480000 thus corresponds to -12.5.

Example 2: -12.55155 decimal = 0xC148D325 hex

| | | | | |
|---------|-----------------|-----------------|-----------------|-----------------|
| Address | +0 | +1 | +2 | +3 |
| Format | SEEEEEEE | EMMMMMMM | MMMMMMMM | MMMMMMMM |
| Binary | 1 1 0 0 0 0 0 1 | 0 1 0 0 1 0 0 0 | 1 1 0 1 0 0 1 1 | 0 0 1 0 0 1 0 1 |
| Hex | C1 | 48 | D3 | 25 |

Example 3: 45.354 decimal = 0x42356A7F hex

| | | | | |
|---------|-----------------|-----------------|-----------------|-----------------|
| Address | +0 | +1 | +2 | +3 |
| Format | SEEEEEEE | EMMMMMMM | MMMMMMMM | MMMMMMMM |
| Binary | 0 1 0 0 0 0 1 0 | 0 0 1 1 0 1 0 1 | 0 1 1 0 1 0 1 0 | 0 1 1 1 1 1 1 1 |
| Hex | 42 | 35 | 6A | 7F |

Exponent: 1000100 bin = 132 dec.

➤ Exp.= 132-127=5

Mantissa: S=0

➤ Sign=positive

0110101011010100111111 bin

Decimal point added to the first position of the mantissa

➤ 0110101011010100111111

Leading 1 in front of the decimal point

➤ 1. 0110101011010100111111

Taking the exponent into account (=5)

➤ 101101.010110101001111111

to the left of the decimal point: 101101 bin = 25+ 23+ 22+20 =

45 dec.

To the right of the decimal point: 010110101001111111 bin =

2-2 + 2-4 + 2-5 + 2-7 + 2-9 + 2-12 + 2-13 + 2-14 + 2-15 + 2-16 + 2-17 + 2-18 = 0.3540001 dec

Final result: +45.03540001 dec.

14.3 Interface parameters

| Baud rate (baud) | Parity | Data bits | Stop bits |
|---------------------------|-----------------|-----------|----------------------------------|
| 4800,9600,19200, 38400 | even, odd, none | 8 | 2 for parity none otherwise 1 |

The maximum data length of a Modbus transmission is 256 bytes. This results in a user data length of 253 bytes.

The number of data bits and stop bits is defined in the Modbus definition. Baud rates of less than 4800 baud are possible by definition, but not implemented at present. The interface parameters can only be configured on the device (not via bus).

14.4 Device settings

The settings are read with the 0x04 command (read input registers) as shown in Table 1. Writing is not possible at present.

| Address | Words | Description | Value | Format |
|---------|-------|---|--|---------------|
| 0xD002 | 2 | Primary transformer measuring voltage | 0 - 999999 V | float |
| 0xD004 | 2 | Secondary transformer measuring voltage | 0 - 999 V | float |
| 0xD006 | 2 | Primary transformer measuring current | 0 - 999999 A | float |
| 0xD008 | 2 | Secondary transformer measuring current | 1 A / 5 A | float |
| 0xD00A | 2 | Target CosPhi 1 | -1.0 - +1.0 | float |
| 0xD00C | 2 | | | float |
| 0xD00E | 2 | Target CosPhi for energy recovery (fixed setting) | -1.0 - +1.0 | float |
| 0xD010 | 2 | Target CosPhi for message "Compensation unit too small" | -1.0 - +1.0 | float |
| 0xD012 | 2 | Connected phase voltage measurement | 0=L1N // 1=L2N // 2=L3N // 4=L12 // 5=L23 // 6=L31 | unsigned long |
| 0xD014 | 2 | Connected phase current measurement | 0=L1 // 1=L2 // 2=L3 // 3=-L1 // 4=-L2 // 5=-L3 | unsigned long |
| 0xD016 | 2 | | | |
| 0xD018 | 2 | | | |
| 0xD01a | 2 | | | |
| 0xD01c | 2 | | | |
| | | General | | |

| Address | Words | Description | Value | Format |
|---------|-------|---|--------|---------------|
| 0xD020 | 2 | Byte sequence for float on the Modbus (1=as defined // 0=reversed) | 0-1 | unsigned long |
| 0xD022 | 2 | Frequency correction (0=Auto // 1=50 Hz // 2=60 Hz) | 0-2 | unsigned long |
| 0xD024 | 2 | Stage monitoring (0=No, 1=Yes) | 0/1 | unsigned long |
| 0xD026 | 2 | Temperature measurement (1=Yes // 0=No) | 0/1 | unsigned long |
| 0xD028 | 2 | Fan relay (1=available // 0=not available) | 0/1 | unsigned long |
| 0xD02a | 2 | Temperature [0.1 °C] that triggers the fan when the threshold is exceeded | 0-700 | unsigned long |
| 0xD02c | 2 | Temperature [0.1 °C] that causes the fan to switch off when the value falls below the threshold | 0-700 | unsigned long |
| 0xD02e | 2 | Temperature [0.1 °C] that triggers the stages when the value falls below the threshold | 0-700 | unsigned long |
| 0xD030 | 2 | Temperature [0.1 °C] that causes the stages to switch off when the threshold is exceeded | 0-700 | unsigned long |
| 0xD032 | 2 | | | |
| 0xD034 | 2 | | | |
| 0xD036 | 2 | | | |
| 0xD038 | 2 | | | |
| 0xD03A | 2 | | | |
| 0xD03C | 2 | | | |
| 0xD03E | 2 | | | |
| | | Switching performance | | |
| 0xD042 | 2 | Percentage of smallest available stage before activation | 70-150 | unsigned long |
| 0xD044 | 2 | Percentage of smallest available stage before stages can be switched off | 70-150 | unsigned long |
| 0xD046 | 2 | Time before message "Compensation unit too small" is displayed [s] | 3-3000 | unsigned long |
| 0xD048 | 2 | Idle time after compensation [s] | 0-300 | unsigned long |
| 0xD04A | 2 | | | unsigned long |
| 0xD04C | 2 | Switching interval [s] | 0-10 | unsigned long |

| Address | Words | Description | Value | Format |
|---------|-------|--|---------------|---------------|
| 0xD04E | 2 | | | unsigned long |
| 0xD050 | 2 | | | unsigned long |
| 0xD052 | 2 | Attenuation coefficient for voltage | 0-9 | unsigned long |
| 0xD054 | 2 | Attenuation coefficient for current | 0-9 | unsigned long |
| 0xD056 | 2 | Attenuation coefficient Q_{miss} | 0-9 | unsigned long |
| 0xD058 | 2 | | | |
| 0xD05A | 2 | | | |
| 0xD05C | 2 | | | |
| 0xD05E | 2 | | | |
| | | Extras | | |
| 0xD062 | 2 | Limit for operating cycle message | 0-999999 | unsigned long |
| 0xD064 | 2 | Low load limit [A] | 0.015 or 0.05 | float |
| 0xD066 | 2 | Time until light load switch-off in minutes | 1-60 | unsigned long |
| 0xD068 | 2 | | | unsigned long |
| 0xD06A | 2 | Voltage harmonic limit [%] | 0-10 | unsigned long |
| 0xD06C | 2 | | | unsigned long |
| 0xD06E | 2 | Modbus address | 1-247 | unsigned long |
| 0xD070 | 2 | Modbus parameters (0=e4800 // 1=o4800 // 2=n4800 // 3=e9600 // 4=o9600 // 5=n9600 // 6=e19200 // 7=o19200 // 8=n19200 // 9=e38400 // 10=o38400 // 11=n38400) | 0-11 | unsigned long |
| 0xD072 | 2 | | | |
| 0xD074 | 2 | | | |
| 0xD076 | 2 | | | |
| 0xD078 | 2 | | | |
| 0xD07A | 2 | | | |
| 0xD07C | 2 | | | |

| Address | Words | Description | Value | Format |
|---------|-------|--|----------------------------|---------------|
| | | Stage parameters | | |
| 0xD080 | 2 | Base index for the following stage parameters (addresses 0xD080 to 0xD08E) | 0 (= stage 1) | unsigned long |
| 0xD082 | 2 | Mode | 0 = Off // 1 = Auto 2 = On | unsigned long |
| 0xD084 | 2 | Stage power [0.1 kvar] | 0-9999 | unsigned long |
| 0xD086 | 2 | Discharge time [s] | 0-999 | unsigned long |
| 0xD088 | 2 | Operating cycles | 0-999999 | unsigned long |
| 0xD08A | 2 | | 0 | unsigned long |
| 0xD08C | 2 | | 0 | unsigned long |
| 0xD08E | 2 | | 0 | unsigned long |
| | | | | |
| 0xD090 | 2 | Base index for the following stage parameters (addresses 0xD090 to 0xD09E) | 1 (= stage 2) | unsigned long |
| | | | | |
| 0xD09E | 2 | | 0 | unsigned long |
| | | | | |
| 0xD0A0 | 2 | Base index for the following stage parameters (addresses 0xD0A0 to 0xD0AE) | 2 (= stage 3) | unsigned long |
| | | | | |
| 0xD0AE | 2 | | 0 | unsigned long |
| | | | | |
| 0xD0B0 | 2 | Base index for the following stage parameters (addresses 0xD0B0 to 0xD0BE) | 3 (= stage 4) | unsigned long |
| | | | | |
| 0xD0BE | 2 | | 0 | unsigned long |
| | | | | |

| Address | Words | Description | Value | Format |
|---------|-------|---|----------------|---------------|
| 0xD0C0 | 2 | Base index for the following stage parameters (addresses 0xD0C0 to 0xD0CE) | 4 (= stage 5) | unsigned long |
| 0xD0CE | 2 | | 0 | unsigned long |
| 0xD0D0 | 2 | Base index for the following stage parameters (addresses 0xD0D0 to 0xD0DE) | 5 (= stage 6) | unsigned long |
| 0xD0DE | 2 | | 0 | unsigned long |
| 0xD0E0 | 2 | Base index for the following stage parameters (addresses 0xD0E0 to 0xD0EE) | 6 (= stage 7) | unsigned long |
| 0xD0EE | 2 | | 0 | unsigned long |
| 0xD0F0 | 2 | Base index for the following stage parameters (addresses 0xD0F0 to 0xD0FE) | 7 (= stage 8) | unsigned long |
| 0xD0FE | 2 | | 0 | unsigned long |
| 0xD100 | 2 | Base index for the following stage parameters (addresses 0xD100 to 0xD10E) | 8 (= stage 9) | unsigned long |
| 0xD10E | 2 | | 0 | unsigned long |
| 0xD110 | 2 | Base index for the following stage parameters (addresses 0xD110 to 0xD11E) | 9 (= stage 10) | unsigned long |
| | | | | |

| Address | Words | Description | Value | Format |
|---------|-------|--|-----------------|---------------|
| 0xD11E | 2 | | 0 | unsigned long |
| 0xD120 | 2 | Base index for the following stage parameters (addresses 0xD120 to 0xD12E) | 10 (= stage 11) | unsigned long |
| 0xD12E | 2 | | 0 | unsigned long |
| 0xD130 | 2 | Base index for the following stage parameters (addresses 0xD130 to 0xD13E) | 11 (= stage 12) | unsigned long |
| 0xD13E | 2 | | 0 | unsigned long |

Request:**01 04 D0 01 00 02 18 CB**

in which

| | |
|-------|---|
| 01 | Device address |
| 04 | Command |
| D0 01 | Read from register 0xD002 "Measuring voltage primary transformer" (in accordance with the Modbus definition, the required address must be set to -1 in the request telex) |
| 00 02 | Read 2 registers, i.e. read 1 data point |
| 18 CB | CRC code |

Response:**01 04 04 44 54 80 00 CF 64**

in which

| | | |
|-------------|---------------------------------------|-------|
| 01 | Device address | |
| 04 | Command | |
| 04 | 4 data bytes | |
| 44 54 80 00 | Primary transformer measuring voltage | 850 V |
| CF 64 | CRC code | |

14.5 Data points

Data points can be read via the command 0x04 (read input registers) in accordance with table 1.

| Address | Words | Description | Unit | Format |
|---------|-------|--|---------|---------------|
| 0x0002 | 2 | Voltage | V | float |
| 0x0004 | 2 | Current | A | float |
| 0x0006 | 2 | Network frequency | Hz | float |
| 0x0008 | 2 | Current CosPhi | | float |
| 0x000a | 2 | Active power | W | float |
| 0x000c | 2 | Fundamental reactive power | var | float |
| 0x000e | 2 | No compensation power | var | float |
| 0x0010 | 2 | Apparent power | VA | float |
| 0x0012 | 2 | THD | % | float |
| 0x0014 | 2 | Temperature | °C | float |
| 0x0016 | 2 | Overtemperature switch-off | | float |
| 0x0018 | 2 | Voltage 3 rd harmonic | % | float |
| 0x001a | 2 | Voltage 5 th harmonic | % | float |
| 0x001c | 2 | Voltage 7 rd harmonic | % | float |
| 0x001e | 2 | Voltage 9 rd harmonic | % | float |
| 0x0020 | 2 | Voltage 11 rd harmonic | % | float |
| 0x0022 | 2 | Voltage 13 rd harmonic | % | float |
| 0x0024 | 2 | Maximum missing compensation power | var | float |
| 0x0026 | 2 | Relay states (12 bit: bit 0 = stage 1 - bit 11 = stage 12 // bit 13 = error message) | bitwise | unsigned long |
| 0x0028 | 2 | Messages (bit coded) | | unsigned long |
| 0x002a | 2 | Error messages (bit coded) | | unsigned long |
| | | | | |

| | | |
|--------------------------------|--------------------|---------------------------------|
| Messages: (display) | Bit 00 set: | No stage power |
| | Bit 01 set: | System temperature switch-off |
| | Bit 02 set: | No measuring current |
| | Bit 03 set: | No measuring voltage |
| | Bit 04 set: | Light load operation |
| | Bit 05 set: | Voltage harmonics limit reached |
| | Bit 06 set: | Operating cycle limit reached |
| | Bit 07 set: | PFC too small |

| | | |
|--|--------------------|---------------------------------|
| Error messages: (relay set) | Bit 00 set: | No stage power |
| | Bit 01 set: | System temperature switch-off |
| | Bit 02 set: | No measuring current |
| | Bit 03 set: | No measuring voltage |
| | Bit 04 set: | Light load operation |
| | Bit 05 set: | Voltage harmonics limit reached |
| | Bit 06 set: | Operating cycle limit reached |
| | Bit 07 set: | PFC too small |

Example Modbus RTU

Request:

01 04 00 01 00 06 21 C8

where

| | |
|-------|---|
| 01 | Device address |
| 04 | Command |
| 00 01 | Read voltage from register 0x0002 (in accordance with Modbus definition, the required address must be set to -1 in the request telex) |
| 00 06 | Read 6 registers, i.e. read 3 data points |
| 21 C8 | CRC code |

Response:

01 04 0C 43 6B 5A B4 42 DC 67 20 42 48 0C 63 AF 7C

in which

| | | |
|-------------|-------------------|-----------|
| 01 | Device address | |
| 04 | Command | |
| 0C | 12 data bytes | |
| 43 6B 5A B4 | Voltage | 235.35 V |
| 42 DC 67 20 | Current | 110.20 A |
| 42 48 0C 63 | Network frequency | 50.012 Hz |
| AF 7C | CRC code | |

15 Device information

The device information is read via the command 0x2B (Read Device Identification)

Information about the manufacturer, device code and device version is read in the process. The device supplies the "Basic Device Identification". "Regular" and "Extended Device Identification" are optional according to the Modbus definition.

Example Modbus RTU

Request:

01 2B 0E 01 00 70 77

in which

| | |
|-------|--|
| 01 | Device address |
| 2B | Command |
| 0E | MEI type according to the Modbus definition always 0x0E |
| 01 | Device ID code for "Basic Device Identification" (see Modbus definition) |
| 00 | Object ID -> in our example manufacturer name, product name and version |
| 70 77 | CRC code |

Response:

01 2B 0E 01 01 00 00 03 00 08 4B 42 52 20 47 6D 62 48 01 12 6D 75 6C 74 69 63 6F 6D 70
20 46 31 34 34

2D 33 20 20 02 09 20 32 2E 30 30 72 30 31 36 CD DB

in which

| | |
|---|--|
| 01 | Device address |
| 2B | Command |
| 0E | MEI type (see Modbus definition) |
| 01 | "Basic identification" (see Modbus definition) |
| 01 | "Conformity level" (see Modbus definition) |
| 00 | No further information follows (no additional telex required) |
| 00 | Next object ID |
| 03 | Number of objects |
| 00 | Object ID 00 |
| 08 | Text length of ID 00 |
| 4B 42 52 20 47 6D 62 48 | "KBR GmbH" |
| 01 | Object ID 01 |
| 12 | Text length of ID 01 |
| 6D 75 6C 74 69 63 6F 6D 70 20 46 31 34 34 1D 33 20 20 | "multicomp F144-3" |
| 02 | Object ID 02 |
| 09 | Text length of ID 02 |
| 20 32 2E 30 30 72 30 31 36 | „2.00r016“ |
| CD DB | CRC code |

Notes

KBR Kompensationsanlagenbau GmbH

Am Kieferschlag 7
D-91126 Schwabach
Germany

T +49 (0) 9122 6373-0
F +49 (0) 9122 6373-83
E info@kbr.de

www.kbr.de